

REFRIGERATOR MANUFACTURER
Turbo air
 more durable, efficient, beautiful

4184 E. Conant St.
 Long Beach, CA 90808
 Tel. 310-900-1000
 Fax. 310-900-1077
www.turboairinc.com

Project :	
Model # :	
Item # :	Qty :
Available W/H :	
Approval :	

Diamond Show Case

Display Cases
 Refrigerated Show Cases

Model : CRT-77-2R



Pass Through

≡ FEATURES & BENEFITS ≡

- **LED lighting interior display system**
 Safety shielded 4 LED lighting system on every corner of the cabinet ensures a longer life and brighter lighting than fluorescent light bulbs, providing attractive, enhanced and shadow-free illumination.
- **Efficient refrigeration system**
 Turbo Air's refrigerators are designed with oversized and balanced R-134A (CFC Free) refrigeration. These include efficient evaporators and condensers for faster cooling and greater efficiency.
- **Beautiful 4 sided glass cabinet allows visibility from all sides to optimize display effect**
- **Compact size and countertop design occupies minimum space but maximize impulse sales**
- **Great space efficiency is ideal for narrow space restaurants and convenience stores**
- **Elegant contemporary Euro design will enhance the interior and space decoration of any store**
- **Sturdy, clean stainless steel shelving**
 Shelves are the most important part of cleanliness as they come in direct contact with food. After a while, PVC coated wire shelves may peel, rust and lead to unsanitary conditions. Only the Turbo Air Diamond Show Case uniquely provides stainless steel shelving.
- **Recommended operating conditions**
 CRT models are designed to operate in environments where temperature & humidity do not exceed 75°F and 55% relative humidity.



Model	Swing Door	CU./FT.	# of Shelves	HP	AMPS	Crated Weight (lbs.)	L x D x H (inches)
CRT-77-2R	2	3.0	3	2/9	2.6	90	163/4 x 167/8 x 381/2

Model : CRT-77-2R

ELECTRICAL DATA	
Voltage	115/60/1
Plug Type	Ⓜ NEMA 5-15P
Full Load Amperes	2.6
Compressor HP	2/9
Refrigerant	R-134A
Cord Length (ft.)	6.5
DIMENSIONAL DATA	
Net Capacity cu. ft.	3
Ext. Length Overall in.	16 ³ / ₄ (425mm)
Ext. Depth Overall in.	16 ⁷ / ₈ (427mm)
Ext. Height Overall in.	38 ¹ / ₂ (978mm)
Int. Length Overall in.	14 ³ / ₈ (366mm)
Int. Depth Overall in.	13 ¹ / ₈ (335mm)
Int. Height Overall in.	25 (635mm)
Net Weight lbs.	82.5
Gross Weight lbs.	90
# of Shelves	3
Self Size	14 ³ / ₈ x 12 ³ / ₄

Design and specifications subject to change without notice.
Actual shipping weight may differ due to extra packing materials for product protection.

- **WARRANTY : 1 Year Parts and Labor Warranty**
Additional 4 Year Warranty on Compressor
- **Self-contained system**

PLAN VIEW

(unit : inch)

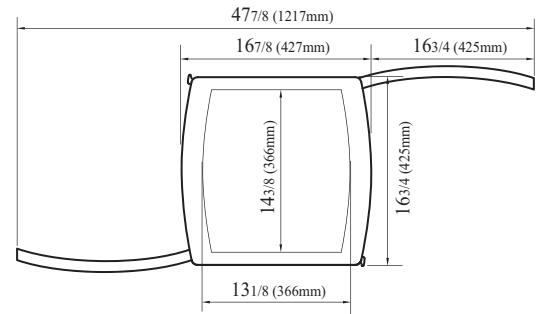

PLAN VIEW

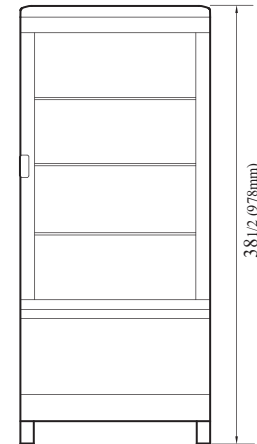

FRONT VIEW

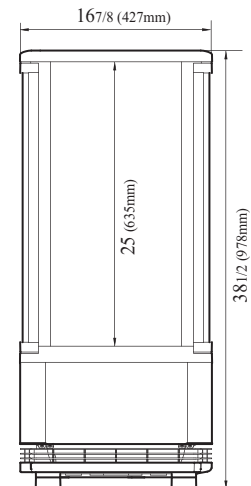

SIDE VIEW

Ver.201501



- Turbo Air : 800-627-0032
- GK : 800-500-3519
- Warranty : 800-381-7770
- AC : 888-900-1002